



User's Manual

Step-Down Transformer

OL6KRT2UTF
OL8K10KRT3UTF
OL6KRT2UTFHW
OL8K10KRT3UTFHW

CyberPower Systems (USA), Inc.

4241 12th Avenue East Suite 400 Shakopee, MN 55379

Phone: 877-297-6937

Fax: 952-403-0009

www.CPSww.com

K01-0000212-01

OVERVIEW

The CyberPower Step-Down Transformers support installation with power cord L6-30P (OL6KRT2UTF / OL8K10KRT3UTF) or hardwire (OL6KRT2UTFHW / OL8K10KRT3UTFHW), and are designed for a variety of CyberPower UPS systems. When combined with the UPS, the Step-Down Transformer converts voltage from 200-240V down to 100-120V.

UNPACKING

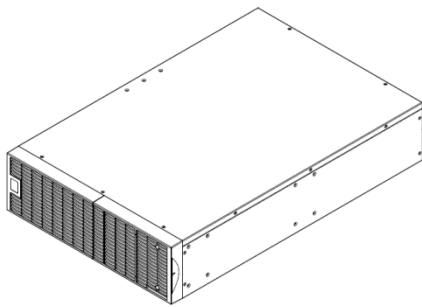
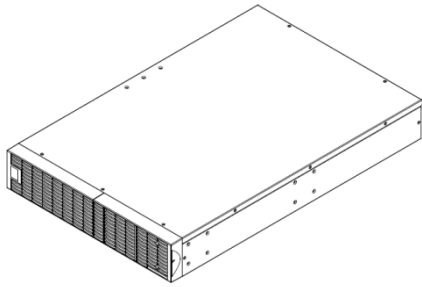

2U or 3U Step-Down Transformer



User's manual



Registration card

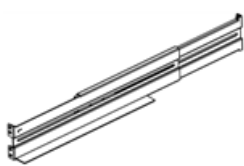

Rackmount left rail

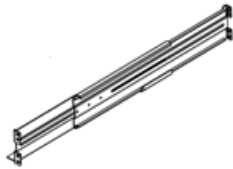

Rackmount right rail

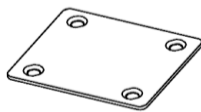

Tie plate (1) * 1 set

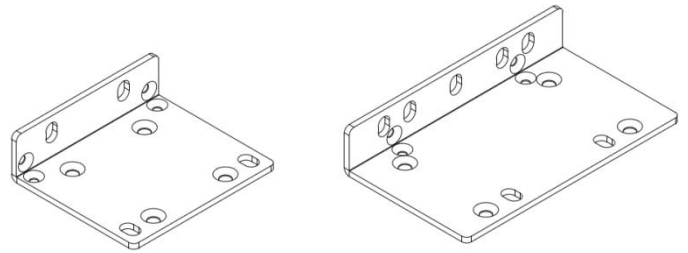

2U or 3U Rackmount ears (Stands) (2) * 1 set



Flat head screws: M5X8L (8) * 1 set



Pan head screws: M5X12L (12) * 1 set



Plastic washers (8) * 1 set



Screw hole dust covers (10) * 1 set

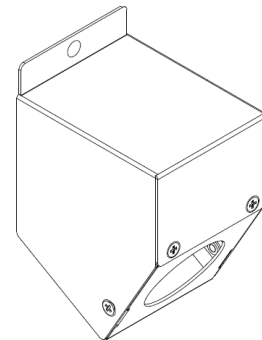

Input terminal block cover

HARDWARE INSTALLATION

HARDWARE INSTALLATION

These versatile Step-Down Transformers can be mounted in a rackmount or vertical tower orientation. This versatility is especially important to growing organizations with changing needs that value having the option to position a Step-Down Transformer on a floor or in a rackmount system. Please follow the instructions below for the respective mounting methods.

SAFETY PRECAUTIONS

CAUTION! To prevent the risk of fire or electric shock, only use the supplied hardware to attach the mounting brackets.

RACKMOUNT INSTALLATION

Step 1: Rackmount ears installation

Attach the two rackmount ears to the Step-Down Transformer using the provided screws M5X8L*8pcs.

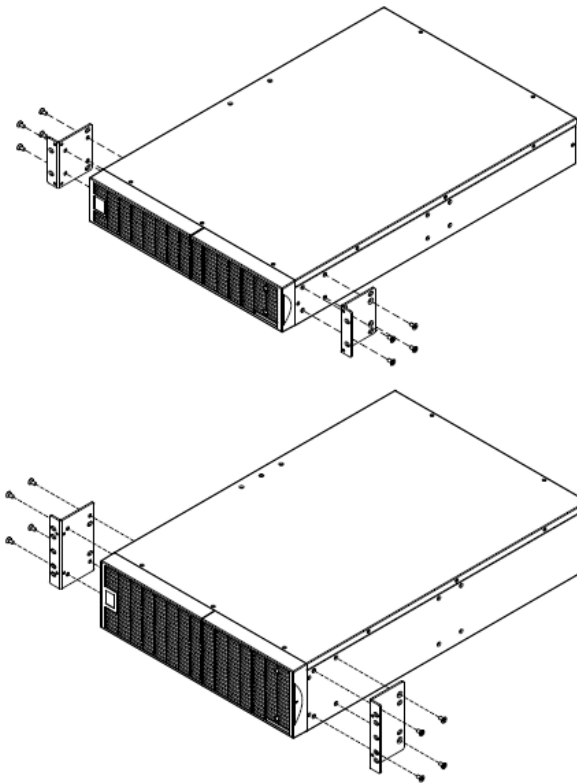

Step 2: Rackmount rail Installation

The rails adjust to mount in 48-cm (19-inch) panel racks from 52 to 91.5cm (20.5 to 36 inches) deep. Select the proper holes in the rack for positioning the Step-Down Transformer in the rack. The 2U Step-Down Transformer takes up position 1 through position 6. The 3U Step-Down Transformer takes up position 1 through position 9.

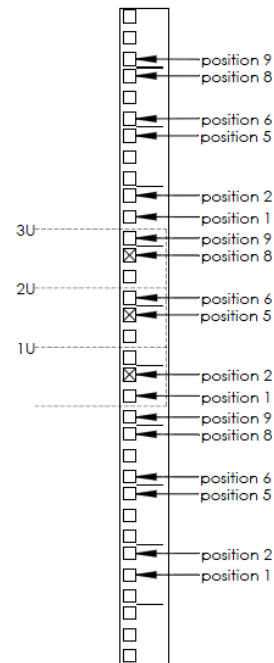

Step 3: Adjust rackmount rails to fit your rack

Attach the rackmount rail to your rack with two M5X12L screws and two plastic washers at the front of the rack. (Located in position 1 & position 6) Do not tighten the screws. Adjust the rail size on the rail assembly of your rack. Secure the rail to the rear of the rack with two M5X12L screws and two plastic washers. Tighten all screws at the front and rear of the rail.

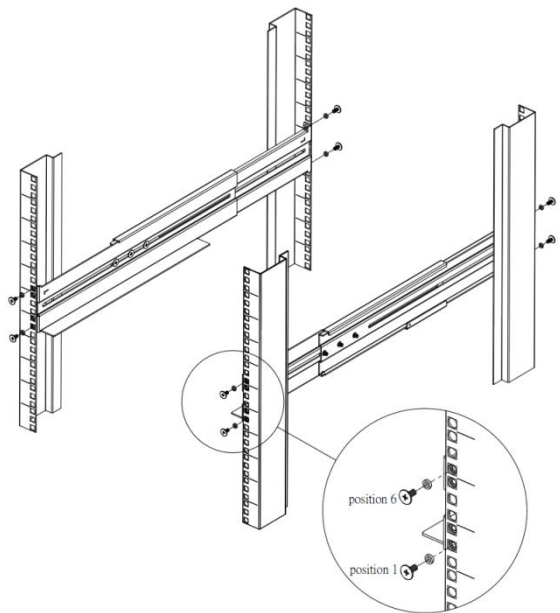

Place the Step-Down Transformer on a flat stable surface with the front of the unit facing toward you. Secure the Step-Down Transformer to your rack with four M5X12L screws at the front of the rack. The 2U Step-Down Transformer takes up position 1 through position 6. The 3U Step-Down Transformer takes up position 1 through position 9.

CAUTION! The Step-Down Transformer must be installed above the power module.

HARDWARE INSTALLATION

VERTICAL/TOWER INSTALLATION

Step 1: Rotate the Multifunction LCD Module

Unscrew the right panel of the power module. Separate the right panel from the UPS. Gently lift the LCD module out. Rotate it to the tower orientation. Reinstall it for a tower configuration.

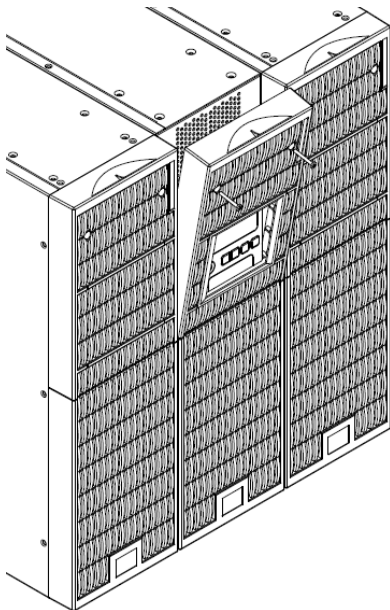
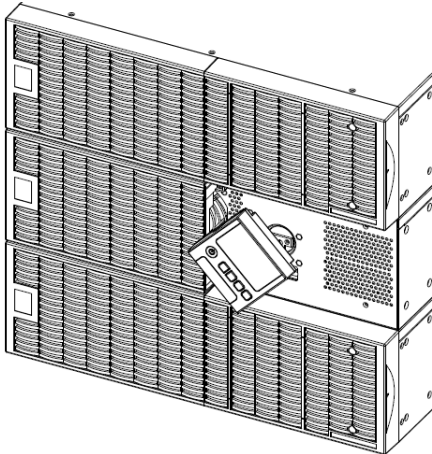
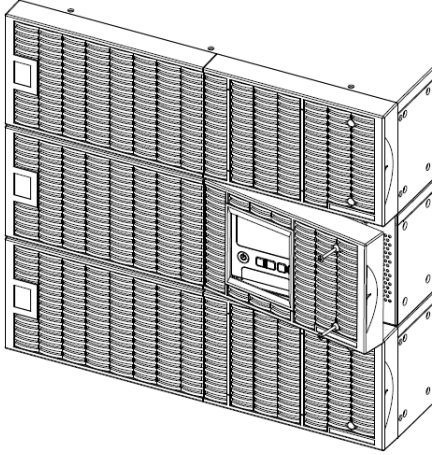

Step 2: Attach the base stands

Secure the tie bracket with the screws (M5X8*4pcs). Tighten the screws (M5X12*4pcs) of the base stands (rackmount ears) onto the bottom of the power module and the Battery module.

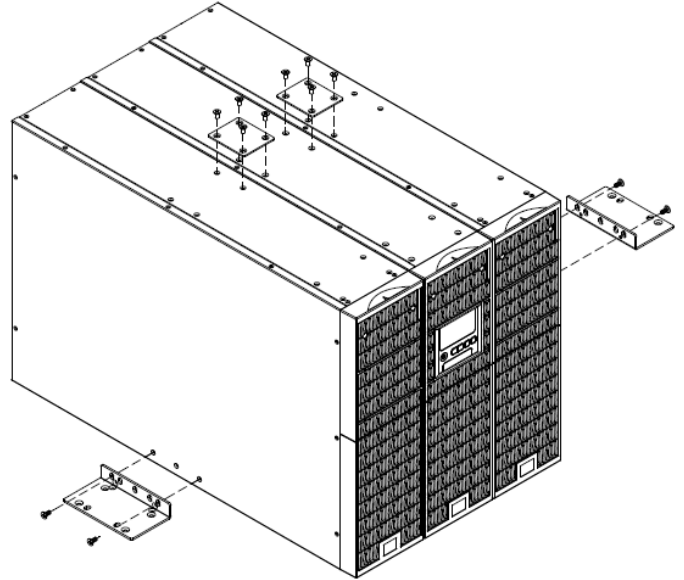

Step 3: Attach dust covers

Insert dust covers into the rackmount ear screw holes that are not being used.

SAFETY PRECAUTIONS

CAUTION! Installation environment should be in a temperature and humidity controlled indoor area free of conductive contaminants. Do not install this UPS where excessive moisture or heat is present (Please see specifications for acceptable temperature and humidity range).

CAUTION! Never install a UPS, or associated wiring or equipment, during a lightning storm.

CAUTION! Do not work alone under hazardous conditions.

CAUTION! In case of the risk of electric shock, do not remove the top cover.

CAUTION! The battery can energize hazardous live parts inside even when the AC input power is disconnected.

HARDWIRING THE INPUT TERMINALS

SAFETY PRECAUTIONS

CAUTION! Input and Output circuit breakers must be "OFF" during the building installation.

CAUTION! The OL6KRT2UTF and OL8K10KRT3UTF with power cord L6-30P DO NOT require hardwiring. Use the attached power cord to connect to the UPS outlet.

CAUTION! The OL6KRT2UTFHW and OL8K10KRT3UTFHW require them to be hard wired into the UPS. Only qualified maintenance personnel should perform this task.

CHECK WIRING

Check wiring dimensions with the following table.

Step-Down Transformers with hardwire	Wiring AWG	Wiring mm ²
OL6KRT2UTFHW	10 AWG	5.5 mm ²
OL8K10KRT3UTFHW	8 AWG	8.0 mm ²

Step 1: Separate the top and bottom covers

Loosen the four screws to separate the top and bottom covers.

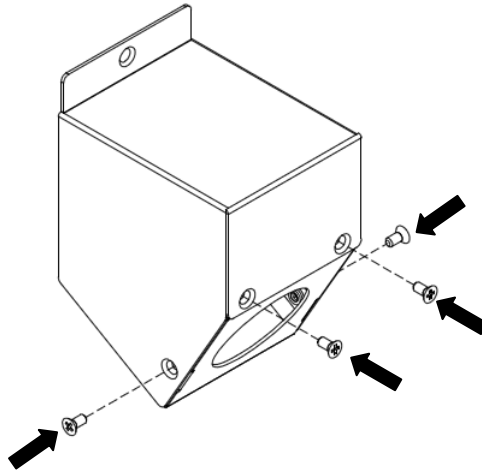

Step 2: Fix the bottom cover on the terminal block

Tighten the two screws to fix the bottom cover on the terminal block.

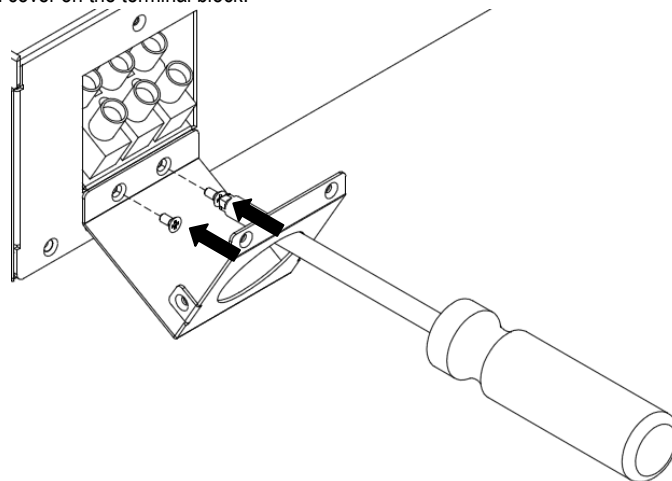

HARDWIRING THE INPUT/ OUTPUT TERMINALS

Step 3: Input configuration

Insert the input cable through the appropriate cable gland (not included).

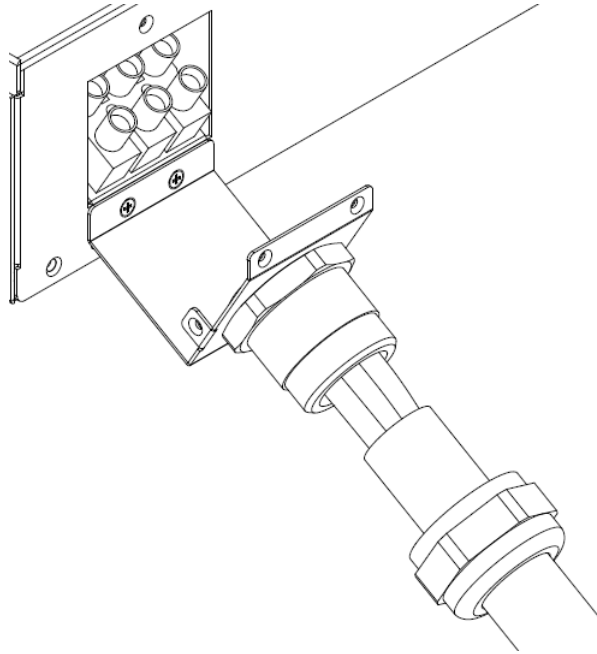

Connect the three wires to the input terminal block.

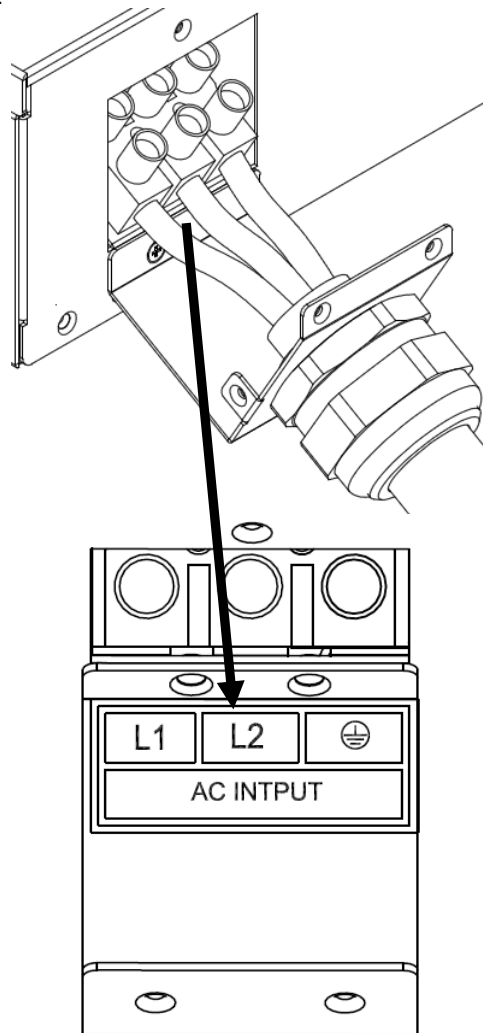

HARDWIRING THE INPUT/ OUTPUT TERMINALS

Step 4: Fix the top cover on the bottom cover

Tighten the five screws to fix the top cover on the bottom cover.

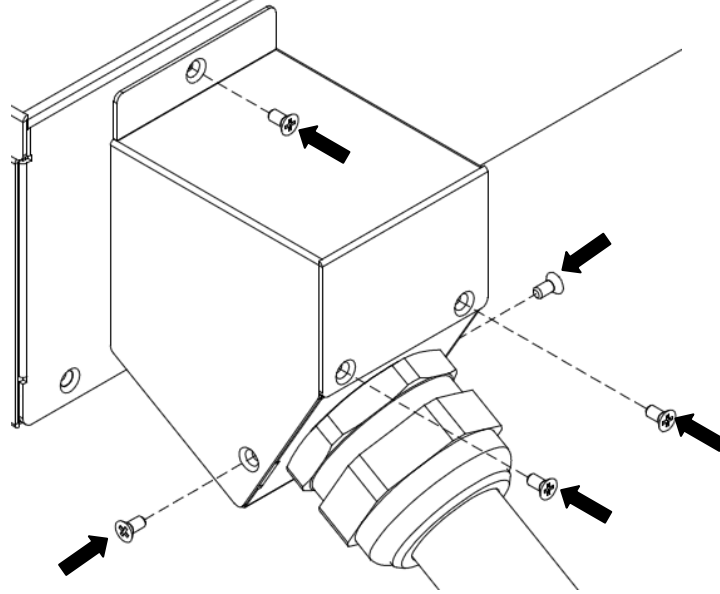

Step 5: Connect the other side of the input cable to UPS output terminal block.

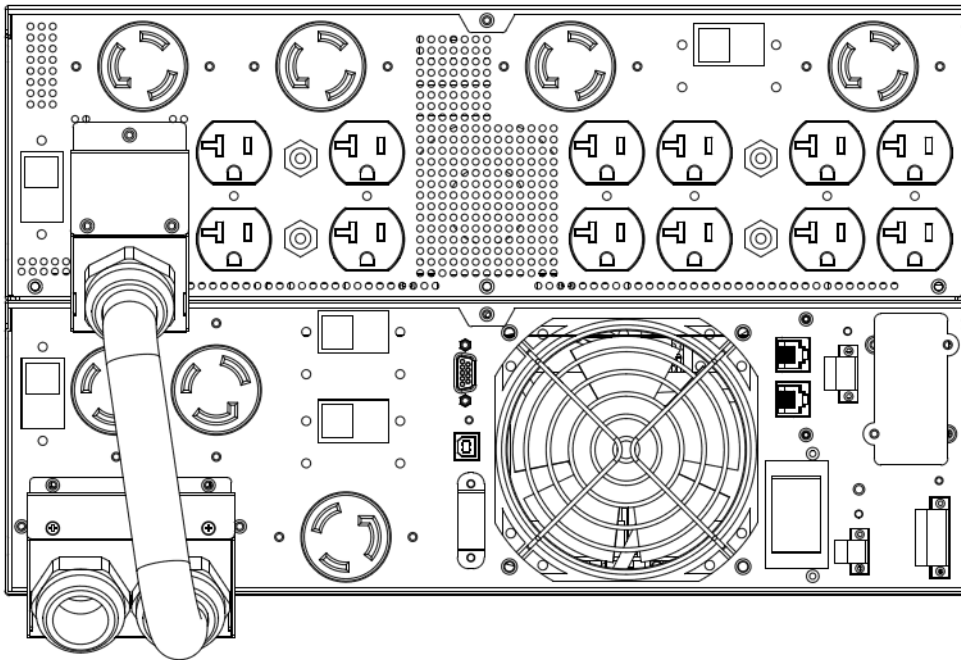

BASIC OPERATION

STEP-DOWN TRANSFORMER FRONT/REAR PANEL DESCRIPTION

1. Input Circuit Breaker

Provides input overload and fault protection.

2. Input Power Cord / Input Terminal Block

Connect to UPS outlet / output terminal block.

3. Battery Backup & Surge Protected Outlets (120Vac)

Provides battery backup and surge protection. They ensure power is provided to connected equipment over a period of time during a power failure.

4. Output Circuit Breaker (120Vac)

Provides output overload and fault protection.

5. Battery Backup & Surge Protected Outlets (208Vac)

Provides battery backup and surge protection. They ensure power is provided to connected equipment over a period of time during a power failure.

6. Output Circuit Breaker (208Vac)

Provides output overload and fault protection.

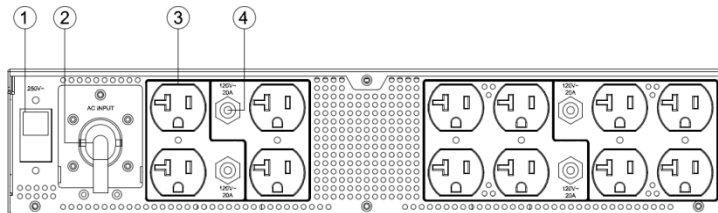
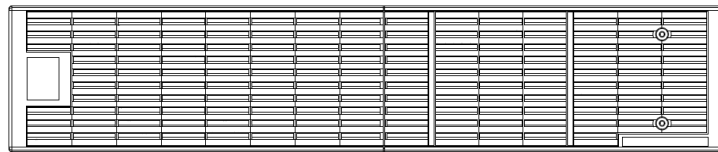

OL6KRT2UTF

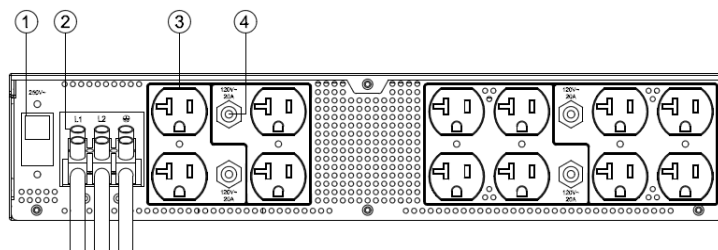

OL6KRT2UTFHW

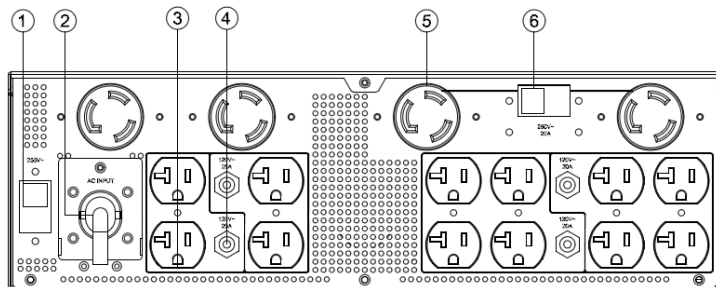
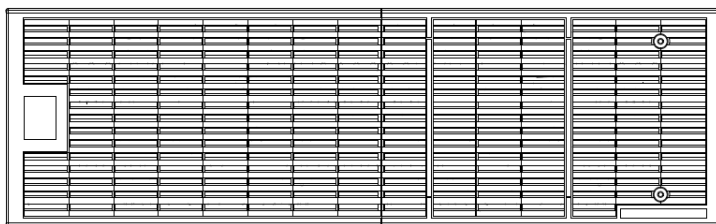

OL8K10KRT3UTF

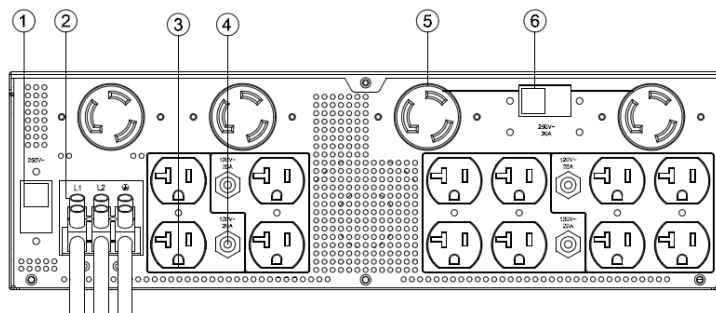

OL8K10KRT3UTFHW

TECHNICAL SPECIFICATIONS

Model	OL6KRT2UTF	OL6KRT2UTFHW	OL8K10KRT3UTF	OL8K10KRT3UTFHW
Configuration				
Maximum Output Power (VA)	5000VA	6000VA	5000VA	8000VA
Maximum Output Power (W)	5000W	5400W	5000W	7200W
Form Factor	Rackmount / Tower			
Input				
Nominal Input Voltage	208Vac			
Input Voltage Range	200-240Vac			
Input Current Rating	24A	30A	24A	40A
Input Frequency	50/60Hz			
Output				
Nominal Output Voltage	120Vac			
UPS Outlets	(12) 5-20R		(12) 5-20R, (2) L6-20R, (2) L6-30R	
Physical				
Dimensions	L x W x H = 26 x 17 x 3.46in. (66 x 43.3 x 8.8cm)		L x W x H = 26 x 17 x 5.2in. (66 x 43.3 x 13.2cm)	
Net Weight	128.3lbs(58.3Kg)		159.7lbs(72.6Kg)	
Environment				
Operating Temperature	32°F to 104°F (0°C to 40°C)			
Operating Relative Humidity	0 to 90% Non-Condensing			
Safety				
Conformance Approvals	CE, UL			

SAFETY PRECAUTIONS

CAUTION! Before connecting to the UPS, check that the input voltage into the UPS is within specifications.

CyberPower Systems Inc.

www.cpsww.com

Entire contents copyright© 2011 CyberPower Systems Inc., All rights reserved. Reproduction in whole or in part without permission is prohibited. PowerPanel® Business Edition and PowerPanel® Personal Edition are trademarks of CyberPower Systems Inc

PRODUCT REGISTRATION

CyberPower requests that you complete and return the Warranty Registration Card enclosed with the Product or register the Product at its website (www.cpsww.com) to establish that you are the Initial Customer of the Product, and therefore entitled coverage under the Limited Warranty and the Connected Equipment Guarantee. (Registration is not required for coverage, but note: if you do not register your purchase, you will be required to provide proof of purchase.)

LIMITED WARRANTY AND CONNECTED EQUIPMENT GUARANTEE

Read the following terms and conditions carefully before using the CyberPower OL6KRT2UTF / OL8K10KRT3UTF / OL6KRT2UTFHW / OL8K10KRT3UTFHW. By using the Product you consent to be bound by and become a party to the terms and conditions of this Limited Warranty and Connected Equipment Guarantee (together referred to as this "Warranty"). If you do not agree to the terms and conditions of this Warranty, you should return the Product for a full refund prior to using it.

Who is Providing this Warranty?

CyberPower Systems (USA), Inc. ("CyberPower") provides this Limited Warranty.

What Does This Warranty Cover?

This warranty covers defects in materials and workmanship in the Product under normal use and conditions. It also covers equipment that was connected to the Product and damaged because of the failure of the Product.

What is the Period of Coverage?

This warranty covers the Product for three years and connected equipment for as long as you own the Product.

Who Is Covered?

This warranty only covers the original purchaser. Coverage ends if you sell or otherwise transfer the Product.

How Do You Get Warranty Service?

1. Before contacting CyberPower, identify Your Product model number, the Purchase Date, and each item of Connected Equipment.
2. Email us at tech@cpsww.com or Call us at (877) 297-6937.
3. If your product requires warranty service you must provide a copy of your dated purchase receipt or invoice.

How Do You Open A Connected Equipment Claim?

1. Call us at (877) 297-6937 or write to us at Cyber Power Systems (USA), Inc., 4241 12th Ave. E., STE 400, Shakopee, MN 55379, or send us an e-mail message at claims@cpsww.com for instructions, within 10 days of the occurrence.
2. When you contact CyberPower, identify the Product, the Purchase Date, and the item(s) of Connected Equipment. Have information on all applicable insurance or other resources of recovery/payment that are available to the Initial Customer and Request a Claim Number.
3. You must provide a dated purchase receipt (or other proof of the original purchase) and provide a description of the damage to your connected equipment.
4. Pack and ship the product to CyberPower and, if requested, the item(s) of Connected Equipment, a repair cost estimate for the damage to the Connected Equipment, and all claim forms that CyberPower provides to you. Show the Claim Number on the shipping label or include it with the product. **You must prepay all shipping costs, you are responsible for packaging and shipment, and you must pay the cost of the repair estimate.**

How Long Do I Have To Make A Claim?

All claims must be made within ten days of the occurrence.

What Will We Do To Correct Problems?

CyberPower will inspect and examine the Product.

If the Product is defective in material or workmanship, CyberPower will repair or replace it at CyberPower's expense, or, if CyberPower is unable to or decides not to repair or replace the Product (if defective) within a reasonable time, CyberPower will refund to you the full purchase price you paid for the Product (purchase receipt showing price paid is required).

LIMITED WARRANTY AND CONNECTED EQUIPMENT GUARANTEE

Who Pays For Shipping?

We pay when we send items to you; you pay when you send items to us.

What Are Some Examples Of What This Warranty Does Not Cover?

1. This Warranty does not cover any software that was damaged or needs to be replaced due to the failure of the Product or any data that is lost as a result of the failure or the restoration of data or records, or the reinstallation of software.
2. This Warranty does not cover or apply to: misuse, modification, operation or storage outside environmental limits of the Product or the equipment connected to it, nor for damage while in transit or in storage, nor if there has been improper operation or maintenance, or use with items not designed or intended for use with the Product, such as laser printers, appliances, aquariums, medical or life support devices, etc.

What Other Limitations Apply?

The sole and exclusive remedies of the Initial Customer are those provided by this Warranty.

1. This Warranty does not apply unless the Product and the equipment that was connected to it were connected to properly wired and grounded outlets (including compliance with electrical and safety codes of the most current electrical code), without the use of any adapters or other connectors.
2. The Product must have been plugged directly into the power source and the equipment connected to the Product must be directly connected to the Product and not "daisy-chained" together in serial fashion with any extension cords, another Product or device similar to the Product, surge suppressor, or power tap. Any such installation voids the Limited Warranty.
3. The Product and equipment connected to it must have been used properly in a suitable and proper environment and in conformance with any license, instruction manual, or warnings provided with the Product and the equipment connected to it.
4. The Product must have been used at all times within the limitations on the Product's VA capacity.

The Product was designed to eliminate disrupting and damaging effects of momentary (less than 1ms) voltage spikes or impulses from lightning or other power transients. If it can be shown that a voltage spike lasting longer than 1ms has occurred, the occurrence will be deemed outside the rated capabilities of the Product and the Limited Warranty is void. CyberPower Does Not Cover or Undertake Any Liability in Any Event for Any of the Following:

1. Loss of or damage to data, records, or software or the restoration of data or records, or the reinstallation of software.
2. Damage from causes other than AC Power Line Transients, spikes, or surges on properly installed, grounded and code-compliant 120 volt power lines in the United States and Canada; transients, surges or spikes on standard telephone land lines, PBX telephone equipment lines or Base 10T Ethernet lines, when properly installed and connected. (This exclusion applies, for example, to fluctuations in data transmission or reception, by CATV or RF transmission or fluctuations, or by transients in such transmission.)
3. Damage from any circumstance described as excluded above with respect to the Product.
4. Damages from fire, flood, wind, rain, rising water, leakage or breakage of plumbing, abuse, misuse or alteration of either the product or the Connected Equipment.
5. CyberPower excludes any liability for personal injury under the Limited Warranty and Connected Equipment Guarantee. CyberPower excludes any liability for direct, indirect, special, incidental or consequential damages, whether for damage to or loss of property [EXCEPT FOR (AND ONLY FOR) the specific limited agreement of CyberPower to provide certain warranty benefits regarding "Connected Equipment" under this Warranty], loss of profits, business interruption, or loss of information or data. NOTE: Some States or Provinces do not allow the exclusion or limitation of incidental or consequential damages, so the above limitation may not apply to you.
6. The Product is not for use in high-risk activities or with aquariums. The Product is not designed or intended for use in hazardous environments requiring fail-safe performance, or for use in any circumstance in which the failure of the Product could lead directly to death, personal injury, or severe physical or property damage, or that would affect operation or safety of any medical or life support device (collectively, "High Risk Activities"). CyberPower expressly disclaims any express or implied warranty of fitness for High Risk Activities or with aquariums. CyberPower does not authorize use of any Product in any High Risk Activities or with Aquariums. **ANY SUCH USE IS IMPROPER AND IS A MISUSE OF THE PRODUCT.**

Where Can I Get More Information?

The application of the United Nations Convention of Contracts for the International Sale of Goods is expressly excluded.

CyberPower is the warrantor under this Limited Warranty.

For further information please feel free to contact CyberPower at CyberPower Systems (USA), Inc. 4241 12th Ave E., STE 400, Shakopee, MN 55379; call us at (877) 297-6937; or send us an e-mail message at claims@cyberpowersystems.com.

CONFORMANCE APPROVALS



FCC Notice

This device complies with part 15 of the FCC Rules. Operation is subject to the following two conditions: (1) This device may not cause harmful interference, and (2) this device must accept any interference that may cause undesired operation.

WARNING!! This equipment has been tested and found to comply with the limits for a Class A digital device, pursuant to part 15 of the FCC Rules. These limits are designed to provide reasonable protection against harmful interference when the equipment is operated in a commercial environment. This equipment generates, uses, and can radiate radio frequency energy and, if not installed and used in accordance with the instruction manual, may cause harmful interference to radio communications. Operation of this equipment in a residential area is likely to cause harmful interference in which case the user will be required to correct the interference at his own expense. Shielded signal cables must be used with this product to ensure compliance with the Class A FCC limits.

The Class A digital apparatus meets all requirements of the Canadian Interference-Causing Equipment Regulation.

Cet appareil numérique de la class A respecte toutes les exigences du Règlement sur le matériel brouilleur du Canada.

This document is believed to be accurate, but CyberPower reserves the right to change or correct the contents and does not assume any responsibility for omissions or errors.

Need Additional Help?

Feel free to contact our Tech Support department with installation, troubleshooting, or general product questions.

CyberPower Technical Support

Phone: 1-877-297-6937

Email: tech@cpsww.com

Web: www.CPSww.com

Mail: 4241 12th Avenue E, Suite 400 Shakopee, MN 55379

Hours of Operation:

Monday – Friday, 8:00am – 5:00pm (CST)

Entire contents copyright © 2011 CyberPower Systems, Inc.

All rights reserved. Reproduction in whole or in part without permission is prohibited.